

For reducing the exhaust noise generated by pneumatic equipment.

Operating pressure: Max. 10 bar
 Operating temperature: -10 °C to +250 °C
 Port: G thread acc. to DIN EN ISO 228-1
 Pore size: 50 µm

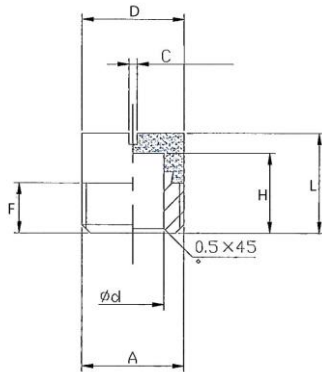

564-1

Silencer, sintered bronze, slotted

Art. No.	Type No.	Thread A	D mm	Ø d mm	F mm	L mm	H mm	C mm
113353	564-1	G 1/8	9.5	5.0	6.5	12.5	8.5	2.0x2.0
100289	564-2	G 1/4	12.6	8.0	6.5	13.5	10.0	1.5x1.5
113354	564-3	G 3/8	16.2	10.0	7.5	16.0	12.5	1.5x1.5
100291	564-4	G 1/2	20.5	15.0	10.0	19.6	15.0	2.5x2.5
113355	564-5	G 3/4	26.0	20.0	11.0	23.0	19.2	1.5x1.5
113356	564-6	G 1	33.0	25.0	13.0	24.0	20.5	1.5x1.5

Flow rates and Noise levels

Art. No.	Type No.	Flow rate l/min.	Noise level, reduced
113353	564-1	110	≥ 15 dB(A)
100289	564-2	380	≥ 15 dB(A)
113354	564-3	430	≥ 20 dB(A)
100291	564-4	810	≥ 20 dB(A)
113355	564-5	2160	≥ 28 dB(A)
113356	564-6	2860	≥ 33 dB(A)

Noise level measurements at $P_1 = 6$ bar, distance 1 m
 Flow at $P_1 = 6$ bar and $\Delta p = 1$ bar

- The use of silencers does not automatically reduce exhaust noise to a safe level. The need for other noise-reducing measures, such as hearing protection, must be assessed as well.
- Uses and applications are the responsibility of the user. However, it is necessary to carry out appropriate tests before use in order to convince yourself of the desired function under the respective conditions. All further claims, in particular liability for consequential damages, are excluded in principle.